

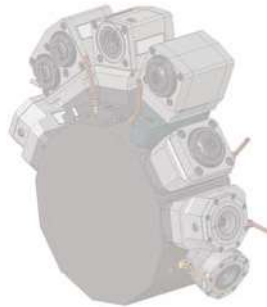

MAZAK

HYPER QUADREX SERIES MULTIPLEX SERIES QUICK TURN NEXUS SERIES

LIVE TOOLS





MAZAK

HYPER QUADREX SERIES

HQR100MSY

HQR150MSY

LIVE TOOLS

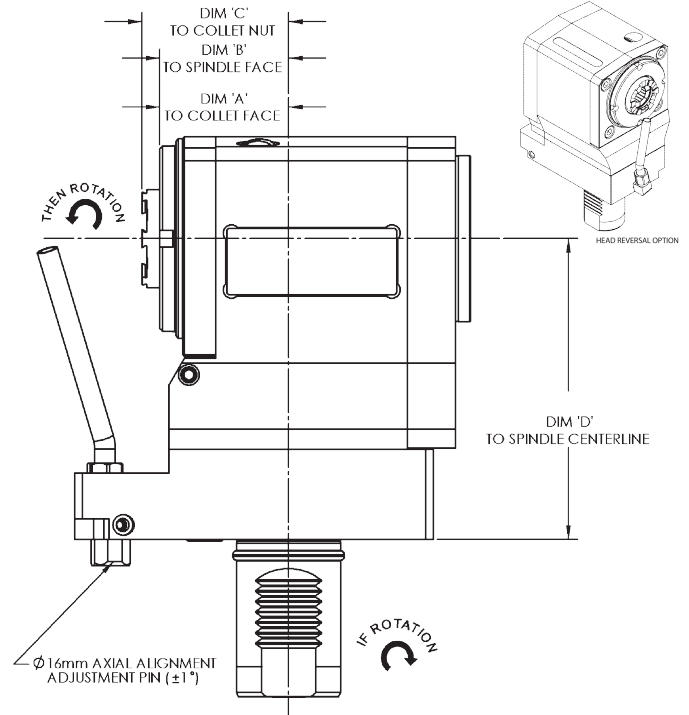

RIGHT-ANGLE (HORIZONTAL)

Item Number	Tool Axis	Ratio	Spindle	Internal Coolant	A (mm)	B (mm)	C (mm)	D (mm)	List Price
DT10211400311	FACE	1:1	ER-32	----	50	50	52	115	\$3,500.00
DT10211400321	FACE	1:1	ER-32	1500 PSI	50	50	58	115	\$4,500.00
DT10221400311	FACE	1:2	ER-32	----	50	50	52	115	\$5,000.00
DT10221400321	FACE	1:2	ER-32	1500 PSI	50	50	58	115	\$6,000.00
DT10241400311	FACE	2:1	ER-32	----	50	50	52	115	\$5,000.00
DT10241400321	FACE	2:1	ER-32	1500 PSI	50	50	58	115	\$6,000.00
DT10411400311	FACE-HR	1:1	ER-32	----	50	50	52	115	\$3,500.00
DT10411400321	FACE-HR	1:1	ER-32	1500 PSI	50	50	58	115	\$4,500.00
DT10421400311	FACE-HR	1:2	ER-32	----	50	50	52	115	\$5,000.00
DT10421400321	FACE-HR	1:2	ER-32	1500 PSI	50	50	58	115	\$6,000.00
DT10441400311	FACE-HR	2:1	ER-32	----	50	50	52	115	\$5,000.00
DT10441400321	FACE-HR	2:1	ER-32	1500 PSI	50	50	58	115	\$6,000.00
DT10210600311	FACE	1:1	KM-40	----	28	40	---	115	\$5,500.00
DT10210600321	FACE	1:1	KM-40	1500 PSI	28	40	---	115	\$6,500.00
DT10410600311	FACE-HR	1:1	KM-40	----	28	40	---	115	\$5,500.00
DT10410600321	FACE-HR	1:1	KM-40	1500 PSI	28	40	---	115	\$6,500.00

HYPER QUADREX SERIES

HQR100MSY

HQR150MSY

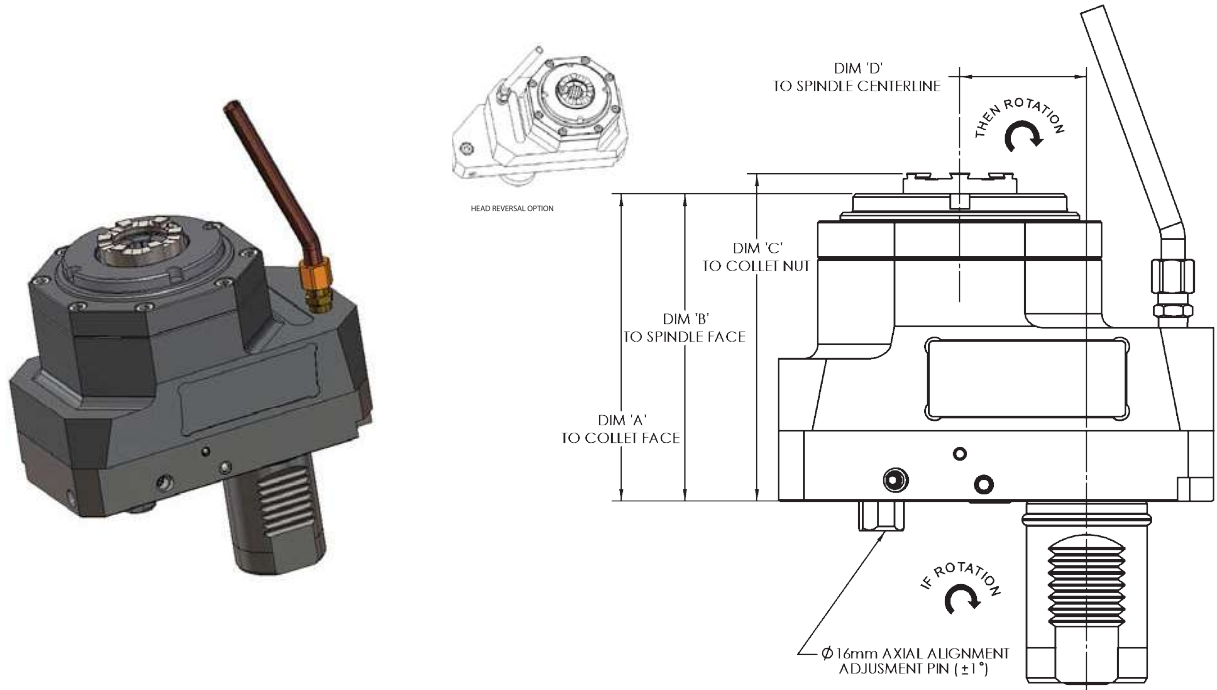

LIVE TOOLS

STRAIGHT-OFFSET (VERTICAL)

Item Number	Tool Axis	Ratio	Spindle	Internal Coolant	A (mm)	B (mm)	C (mm)	D (mm)	List Price
DT10111400311	OD	1:1	ER-32	----	102	102	104	42	\$3,500.00
DT10111400321	OD	1:1	ER-32	1500 PSI	102	102	110	42	\$4,500.00
DT10121400311	OD	1:2	ER-32	----	102	102	104	42	\$5,000.00
DT10121400321	OD	1:2	ER-32	1500 PSI	102	102	110	42	\$6,000.00
DT10141400311	OD	2:1	ER-32	----	102	102	104	42	\$5,000.00
DT10141400321	OD	2:1	ER-32	1500 PSI	102	102	110	42	\$6,000.00
DT10311400311	OD-HR	1:1	ER-32	----	102	102	104	42	\$3,500.00
DT10311400321	OD-HR	1:1	ER-32	1500 PSI	102	102	110	42	\$4,500.00
DT10321400311	OD-HR	1:2	ER-32	----	102	102	104	42	\$5,000.00
DT10321400321	OD-HR	1:2	ER-32	1500 PSI	102	102	110	42	\$6,000.00
DT10341400311	OD-HR	2:1	ER-32	----	102	102	104	42	\$5,000.00
DT10341400321	OD-HR	2:1	ER-32	1500 PSI	102	102	110	42	\$6,000.00
DT10110600311	OD	1:1	KM-40	----	90	102	---	42	\$5,500.00
DT10110600321	OD	1:1	KM-40	1500 PSI	90	102	---	42	\$6,500.00
DT10310600311	OD-HR	1:1	KM-40	----	90	102	---	42	\$5,500.00
DT10310600321	OD-HR	1:1	KM-40	1500 PSI	90	102	---	42	\$6,500.00



MAZAK

HYPER QUADREX SERIES

HQR200MSY

LIVE TOOLS

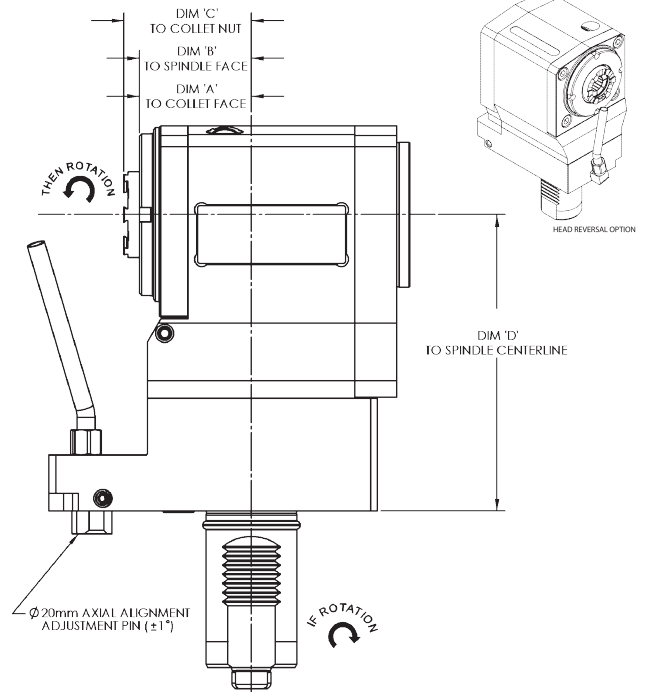

RIGHT-ANGLE (HORIZONTAL)

Item Number	Tool Axis	Ratio	Spindle	Internal Coolant	A (mm)	B (mm)	C (mm)	D (mm)	List Price
DT10211400411	FACE	1:1	ER-32	----	50	50	52	130	\$3,500.00
DT10211400421	FACE	1:1	ER-32	1500 PSI	50	50	58	130	\$4,500.00
DT10221400411	FACE	1:2	ER-32	----	50	50	52	130	\$5,000.00
DT10221400421	FACE	1:2	ER-32	1500 PSI	50	50	58	130	\$6,000.00
DT10241400411	FACE	2:1	ER-32	----	50	50	52	130	\$5,000.00
DT10241400421	FACE	2:1	ER-32	1500 PSI	50	50	58	130	\$6,000.00
DT10411400411	FACE-HR	1:1	ER-32	----	50	50	52	130	\$3,500.00
DT10411400421	FACE-HR	1:1	ER-32	1500 PSI	50	50	58	130	\$4,500.00
DT10421400411	FACE-HR	1:2	ER-32	----	50	50	52	130	\$5,000.00
DT10421400421	FACE-HR	1:2	ER-32	1500 PSI	50	50	58	130	\$6,000.00
DT10441400411	FACE-HR	2:1	ER-32	----	50	50	52	130	\$5,000.00
DT10441400421	FACE-HR	2:1	ER-32	1500 PSI	50	50	58	130	\$6,000.00
DT10210600411	FACE	1:1	KM-40	----	28	40	---	130	\$5,500.00
DT10210600421	FACE	1:1	KM-40	1500 PSI	28	40	---	130	\$6,500.00
DT10410600411	FACE-HR	1:1	KM-40	----	28	40	---	130	\$5,500.00
DT10410600421	FACE-HR	1:1	KM-40	1500 PSI	28	40	---	130	\$6,500.00

HQR200MSY

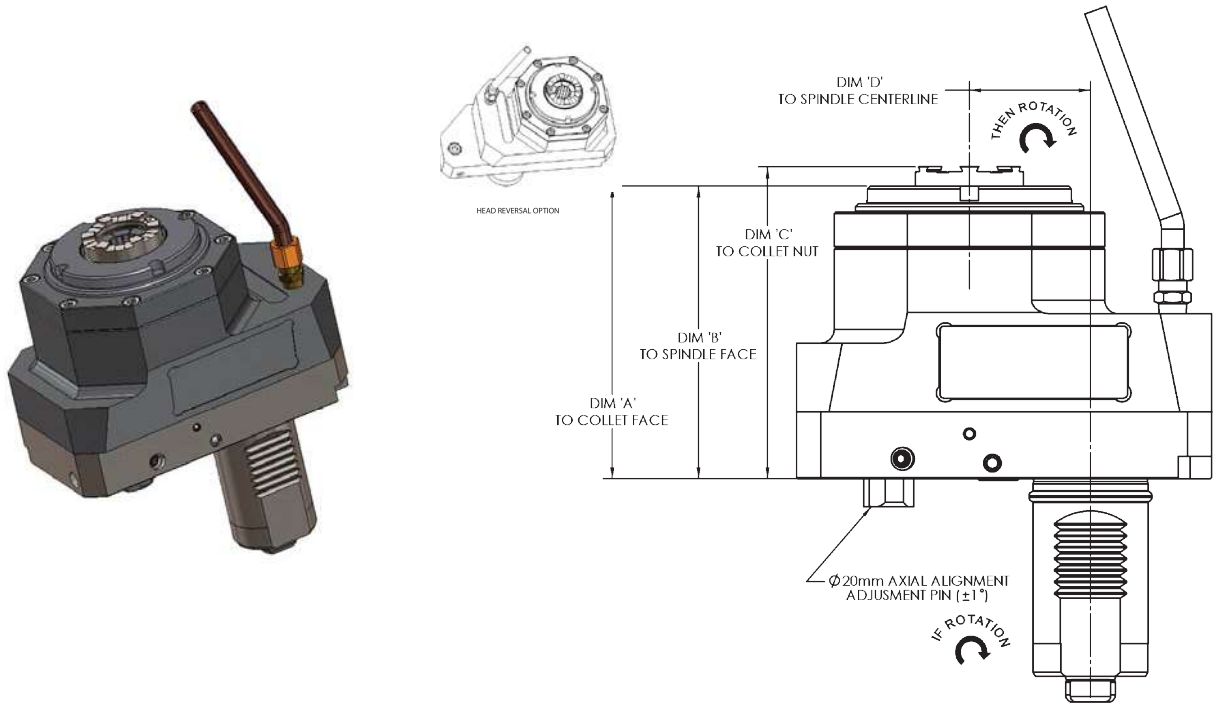

LIVE TOOLS

STRAIGHT-OFFSET (VERTICAL)

Item Number	Tool Axis	Ratio	Spindle	Internal Coolant	A (mm)	B (mm)	C (mm)	D (mm)	List Price
DT10111400411	OD	1:1	ER-32	----	102	102	104	42	\$3,500.00
DT10111400421	OD	1:1	ER-32	1500 PSI	102	102	110	42	\$4,500.00
DT10121400411	OD	1:2	ER-32	----	102	102	104	42	\$5,000.00
DT10121400421	OD	1:2	ER-32	1500 PSI	102	102	110	42	\$6,000.00
DT10141400411	OD	2:1	ER-32	----	102	102	104	42	\$5,000.00
DT10141400421	OD	2:1	ER-32	1500 PSI	102	102	110	42	\$6,000.00
DT10311400411	OD-HR	1:1	ER-32	----	102	102	104	42	\$3,500.00
DT10311400421	OD-HR	1:1	ER-32	1500 PSI	102	102	110	42	\$4,500.00
DT10321400411	OD-HR	1:2	ER-32	----	102	102	104	42	\$5,000.00
DT10321400421	OD-HR	1:2	ER-32	1500 PSI	102	102	110	42	\$6,000.00
DT10341400411	OD-HR	2:1	ER-32	----	102	102	104	42	\$5,000.00
DT10341400421	OD-HR	2:1	ER-32	1500 PSI	102	102	110	42	\$6,000.00
DT10110600411	OD	1:1	KM-40	----	90	102	---	42	\$5,500.00
DT10110600421	OD	1:1	KM-40	1500 PSI	90	102	---	42	\$6,500.00
DT10310600411	OD-HR	1:1	KM-40	----	90	102	---	42	\$5,500.00
DT10310600421	OD-HR	1:1	KM-40	1500 PSI	90	102	---	42	\$6,500.00



MAZAK

HYPER QUADREX SERIES

HQR450M

LIVE TOOLS

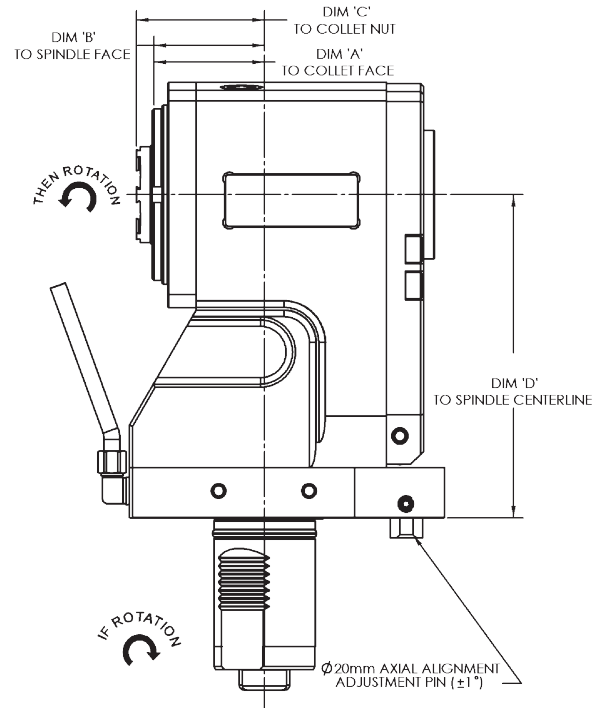

RIGHT-ANGLE (HORIZONTAL)

Item Number	Tool Axis	Ratio	Spindle	Internal Coolant	A (mm)	B (mm)	C (mm)	D (mm)	List Price
DT10211500611	FACE	1:1	ER-40	----	56	56	58	160	\$4,500.00
DT10211500621	FACE	1:1	ER-40	1500 PSI	56	56	64	160	\$5,500.00
DT10221500611	FACE	1:2	ER-40	----	56	56	58	160	\$6,000.00
DT10221500621	FACE	1:2	ER-40	1500 PSI	56	56	64	160	\$7,000.00
DT10241500611	FACE	2:1	ER-40	----	56	56	58	160	\$6,000.00
DT10241500621	FACE	2:1	ER-40	1500 PSI	56	56	64	160	\$7,000.00
DT10210500611	FACE	1:1	KM-50	----	32	48	---	160	\$7,500.00
DT10210500621	FACE	1:1	KM-50	1500 PSI	32	48	---	160	\$8,500.00

HQR450M

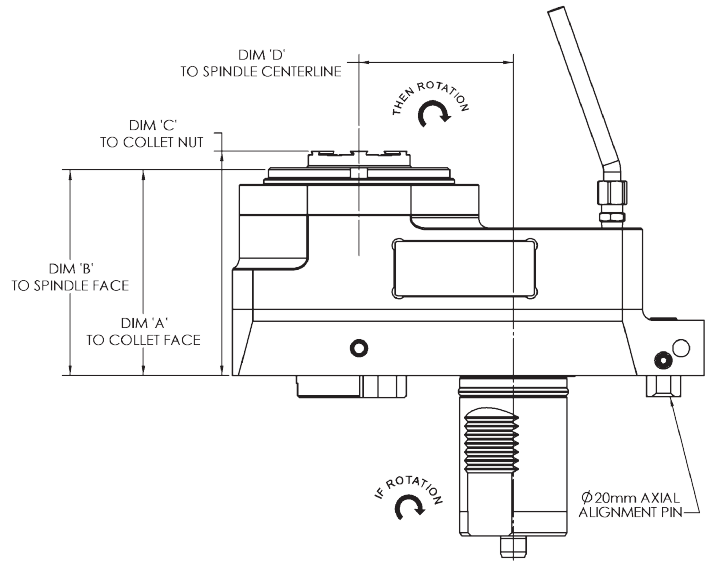

LIVE TOOLS

STRAIGHT-OFFSET (VERTICAL)

Item Number	Tool Axis	Ratio	Spindle	Internal Coolant	A (mm)	B (mm)	C (mm)	D (mm)	List Price
DT10111500611	OD	1:1	ER-40	----	96	96	99	72	\$4,500.00
DT10111500621	OD	1:1	ER-40	1500 PSI	96	96	105	72	\$5,500.00
DT10121500611	OD	1:2	ER-40	----	96	96	99	72	\$6,000.00
DT10121500621	OD	1:2	ER-40	1500 PSI	96	96	105	72	\$7,000.00
DT10141500611	OD	2:1	ER-40	----	96	96	99	72	\$6,000.00
DT10141500621	OD	2:1	ER-40	1500 PSI	96	96	105	72	\$7,000.00
DT10110500611	OD	1:1	KM-50	----	100	114	---	72	\$7,500.00
DT10110500621	OD	1:1	KM-50	1500 PSI	100	114	---	72	\$8,500.00



MAZAK

HYPER QUADREX SERIES

HQR100MSY HQR150MSY

HQR200MSY

HQR450M

LIVE TOOLS

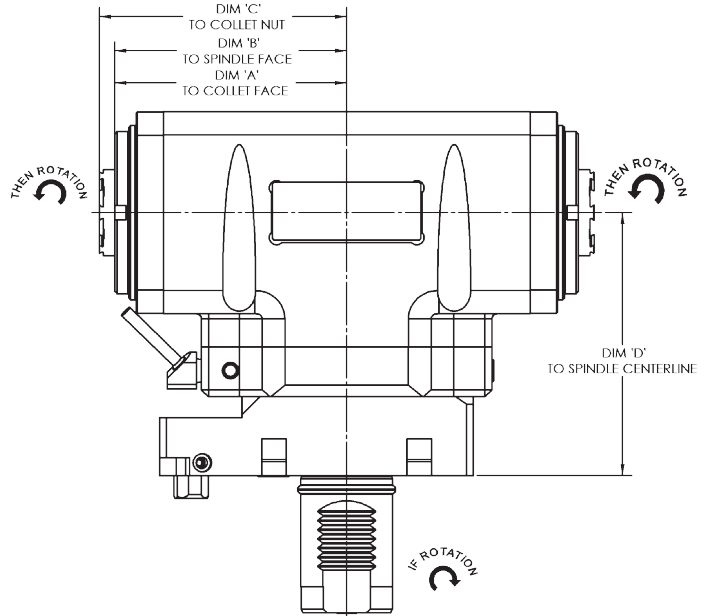
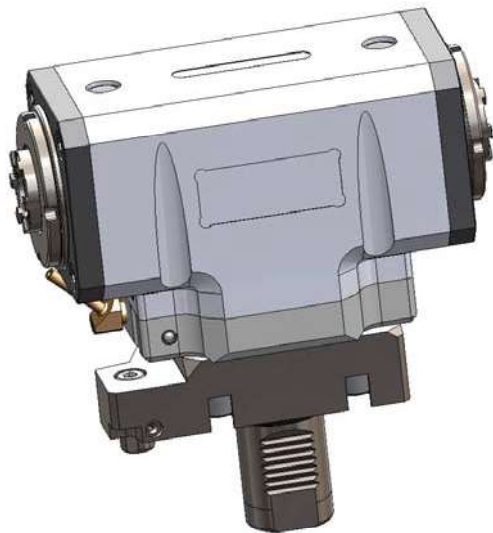

RIGHT-ANGLE DUAL-HEAD (HORIZONTAL)

HQR100MSY HQR150MSY

Item Number	Tool Axis	Ratio	Spindle	Internal Coolant	A (mm)	B (mm)	C (mm)	D (mm)	List Price
DT10511400311	FACE-DH	1:1	ER-32	----	101	101	103	115	\$5,000.00
DT10511400321	FACE-DH	1:1	ER-32	1500 PSI	101	101	108	115	\$6,500.00

HQR200MSY

Item Number	Tool Axis	Ratio	Spindle	Internal Coolant	A (mm)	B (mm)	C (mm)	D (mm)	List Price
DT10511400411	FACE-DH	1:1	ER-32	----	101	101	103	130	\$5,000.00
DT10511400421	FACE-DH	1:1	ER-32	1500 PSI	101	101	108	130	\$6,500.00

HYPER QUADREX SERIES

HQR100MSY HQR150MSY

HQR200MSY

HQR450M

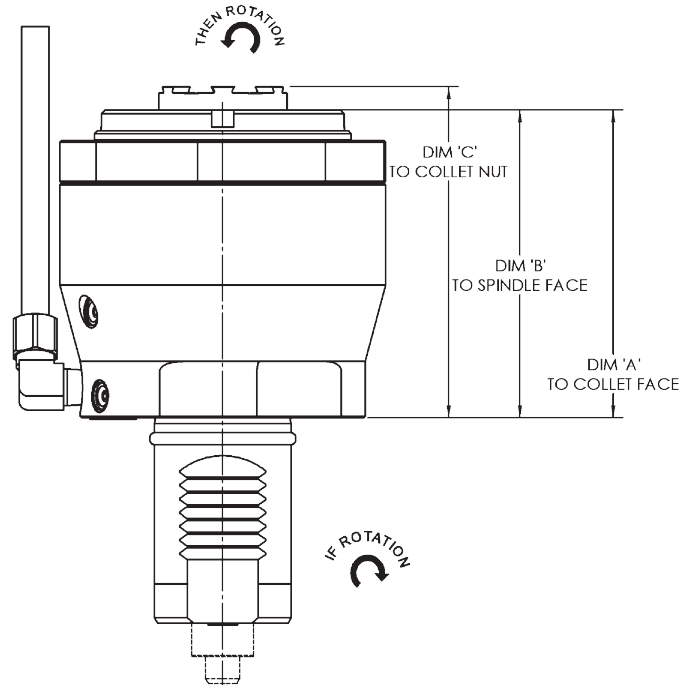

LIVE TOOLS

STRAIGHT (VERTICAL)

HQR100MSY HQR150MSY

Item Number	Tool Axis	Ratio	Spindle	Internal Coolant	A (mm)	B (mm)	C (mm)	D (mm)	List Price
DT10611400311	OD	1:1	ER-32	----	64	64	66	---	\$2,000.00
DT10611400321	OD	1:1	ER-32	1500 PSI	90	90	98	---	\$3,500.00

HQR200MSY

Item Number	Tool Axis	Ratio	Spindle	Internal Coolant	A (mm)	B (mm)	C (mm)	D (mm)	List Price
DT10611400411	OD	1:1	ER-32	----	64	64	66	---	\$2,000.00
DT10611400421	OD	1:1	ER-32	1500 PSI	90	90	98	---	\$3,500.00

HQR450M

Item Number	Tool Axis	Ratio	Spindle	Internal Coolant	A (mm)	B (mm)	C (mm)	D (mm)	List Price
DT10611500511	OD	1:1	ER-40	----	78	78	81	---	\$3,000.00
DT10611500521	OD	1:1	ER-40	1500 PSI	102	102	111	---	\$4,500.00



MAZAK

MULTIPLEX SERIES

MPX6100 (Y)

LIVE TOOLS

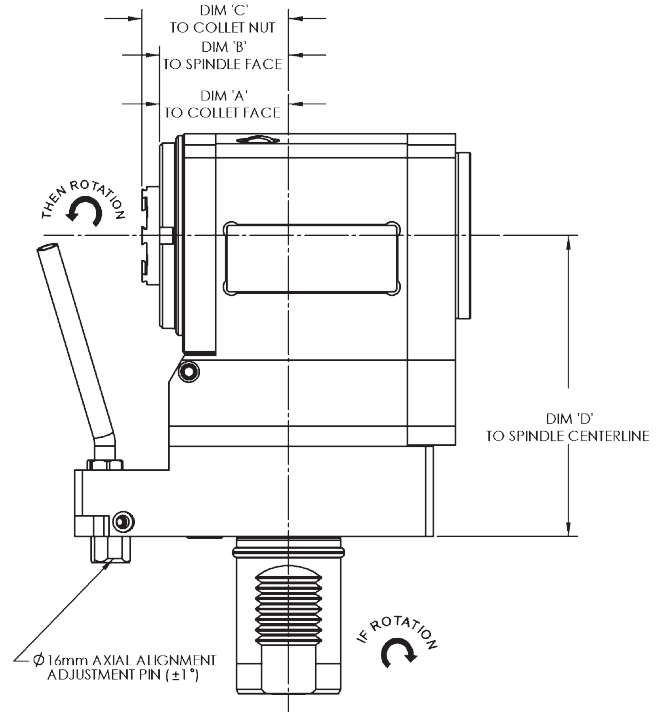

RIGHT-ANGLE (HORIZONTAL)

Item Number	Tool Axis	Ratio	Spindle	Internal Coolant	A (mm)	B (mm)	C (mm)	D (mm)	List Price
DT10211400311	FACE	1:1	ER-32	----	50	50	52	115	\$3,500.00
DT10211400321	FACE	1:1	ER-32	1500 PSI	50	50	58	115	\$4,500.00
DT10221400311	FACE	1:2	ER-32	----	50	50	52	115	\$5,000.00
DT10221400321	FACE	1:2	ER-32	1500 PSI	50	50	58	115	\$6,000.00
DT10241400311	FACE	2:1	ER-32	----	50	50	52	115	\$5,000.00
DT10241400321	FACE	2:1	ER-32	1500 PSI	50	50	58	115	\$6,000.00
DT10210600311	FACE	1:1	KM-40	----	28	40	---	115	\$5,500.00
DT10210600321	FACE	1:1	KM-40	1500 PSI	28	40	---	115	\$6,500.00

MPX6100 (Y)

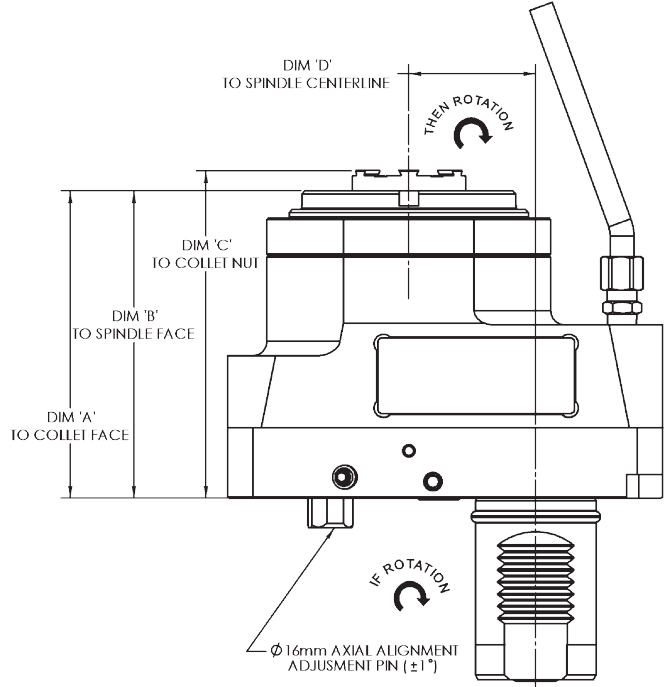

LIVE TOOLS

STRAIGHT-OFFSET (VERTICAL)

Item Number	Tool Axis	Ratio	Spindle	Internal Coolant	A (mm)	B (mm)	C (mm)	D (mm)	List Price
DT10111400311	OD	1:1	ER-32	----	102	102	104	42	\$3,500.00
DT10111400321	OD	1:1	ER-32	1500 PSI	102	102	110	42	\$4,500.00
DT10121400311	OD	1:2	ER-32	----	102	102	104	42	\$5,000.00
DT10121400321	OD	1:2	ER-32	1500 PSI	102	102	110	42	\$6,000.00
DT10141400311	OD	2:1	ER-32	----	102	102	104	42	\$5,000.00
DT10141400321	OD	2:1	ER-32	1500 PSI	102	102	110	42	\$6,000.00
DT10110600311	OD	1:1	KM-40	----	90	102	---	42	\$5,500.00
DT10110600321	OD	1:1	KM-40	1500 PSI	90	102	---	42	\$6,500.00



MAZAK

MULTIPLEX SERIES

MPX6200 (Y)

MPX6250

MPX8200

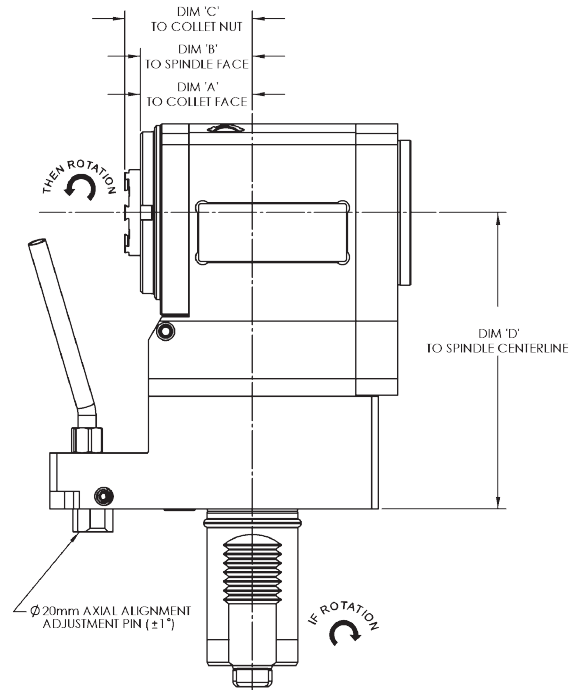

RIGHT-ANGLE (HORIZONTAL)

Item Number	Tool Axis	Ratio	Spindle	Internal Coolant	A (mm)	B (mm)	C (mm)	D (mm)	List Price
DT10211400411	FACE	1:1	ER-32	----	50	50	52	130	\$3,500.00
DT10211400421	FACE	1:1	ER-32	1500 PSI	50	50	58	130	\$4,500.00
DT10221400411	FACE	1:2	ER-32	----	50	50	52	130	\$5,000.00
DT10221400421	FACE	1:2	ER-32	1500 PSI	50	50	58	130	\$6,000.00
DT10241400411	FACE	2:1	ER-32	----	50	50	52	130	\$5,000.00
DT10241400421	FACE	2:1	ER-32	1500 PSI	50	50	58	130	\$6,000.00
DT10210600411	FACE	1:1	KM-40	----	28	40	---	130	\$5,500.00
DT10210600421	FACE	1:1	KM-40	1500 PSI	28	40	---	130	\$6,500.00

LIVE TOOLS

MULTIPLEX SERIES

MPX6200 (Y)

MPX6250

MPX8200

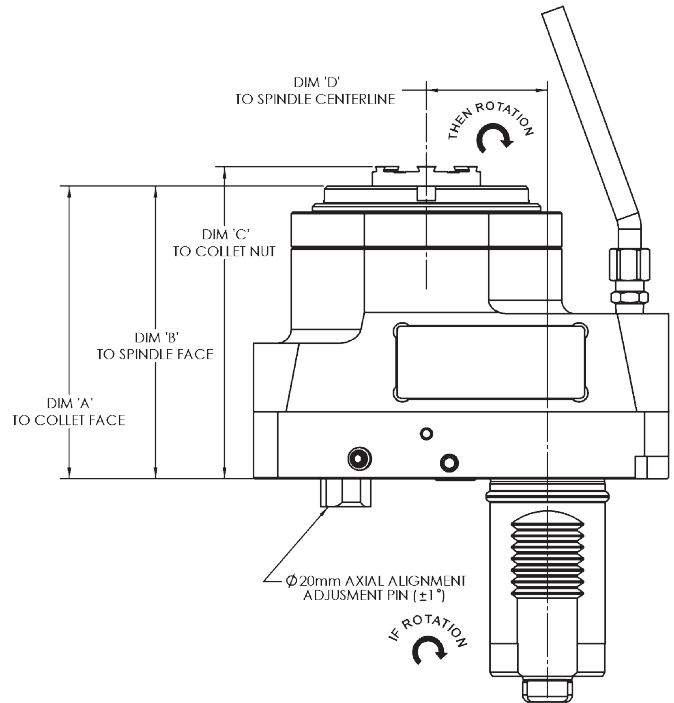

LIVE TOOLS

STRAIGHT-OFFSET (VERTICAL)

Item Number	Tool Axis	Ratio	Spindle	Internal Coolant	A (mm)	B (mm)	C (mm)	D (mm)	List Price
DT10111400411	OD	1:1	ER-32	----	102	102	104	42	\$3,500.00
DT10111400421	OD	1:1	ER-32	1500 PSI	102	102	110	42	\$4,500.00
DT10121400411	OD	1:2	ER-32	----	102	102	104	42	\$5,000.00
DT10121400421	OD	1:2	ER-32	1500 PSI	102	102	110	42	\$6,000.00
DT10141400411	OD	2:1	ER-32	----	102	102	104	42	\$5,000.00
DT10141400421	OD	2:1	ER-32	1500 PSI	102	102	110	42	\$6,000.00
DT10110600411	OD	1:1	KM-40	----	90	102	---	42	\$5,500.00
DT10110600421	OD	1:1	KM-40	1500 PSI	90	102	---	42	\$6,500.00



MAZAK

MULTIPLEX SERIES

MPX6300 (Y)

LIVE TOOLS

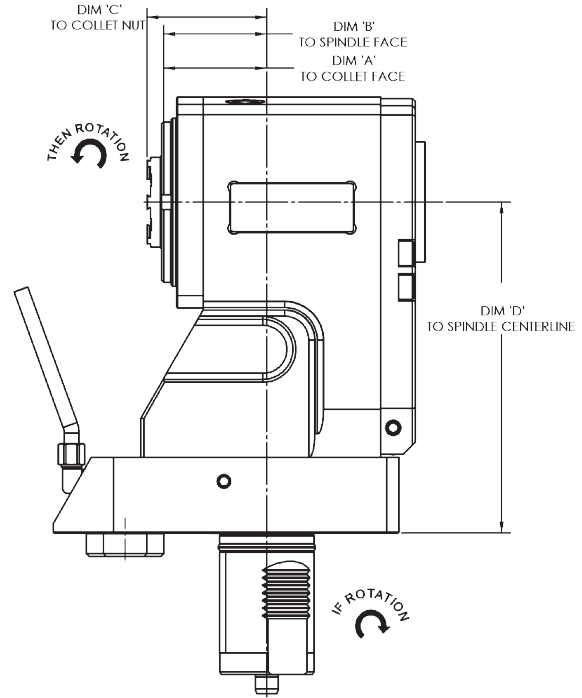
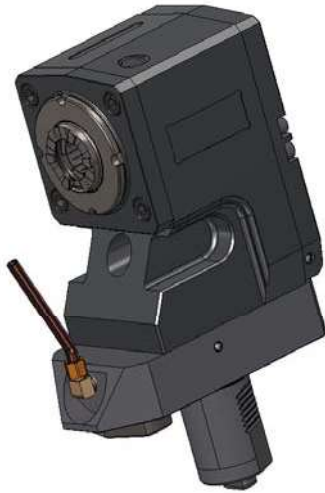

RIGHT-ANGLE (HORIZONTAL)

Item Number	Tool Axis	Ratio	Spindle	Internal Coolant	A (mm)	B (mm)	C (mm)	D (mm)	List Price
DT10211500511	FACE	1:1	ER-40	----	55	55	58	175	\$4,500.00
DT10211500521	FACE	1:1	ER-40	1500 PSI	55	55	64	175	\$5,500.00
DT10221500511	FACE	1:2	ER-40	----	55	55	58	175	\$6,000.00
DT10221500521	FACE	1:2	ER-40	1500 PSI	55	55	64	175	\$7,000.00
DT10241500511	FACE	2:1	ER-40	----	55	55	58	175	\$6,000.00
DT10241500521	FACE	2:1	ER-40	1500 PSI	55	55	64	175	\$7,000.00
DT10210500511	FACE	1:1	KM-50	----	32	48	---	175	\$7,500.00
DT10210500521	FACE	1:1	KM-50	1500 PSI	32	48	---	175	\$8,500.00

MPX6300 (Y)

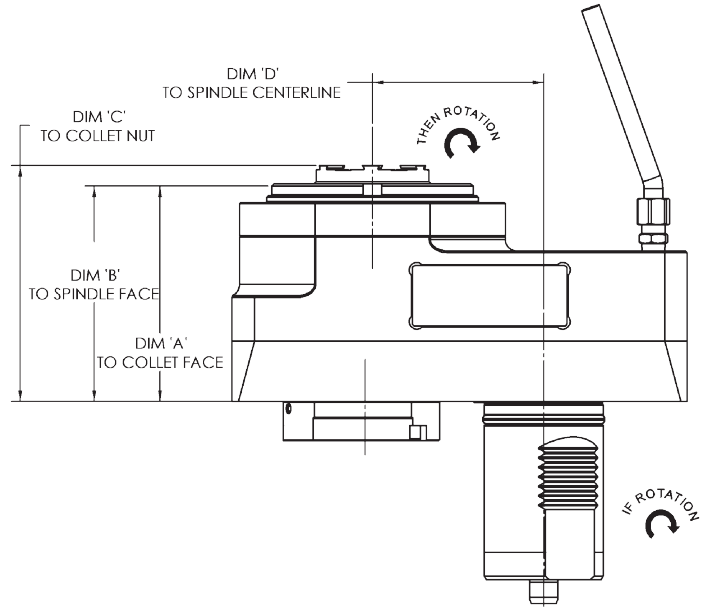

LIVE TOOLS

STRAIGHT-OFFSET (VERTICAL)

Item Number	Tool Axis	Ratio	Spindle	Internal Coolant	A (mm)	B (mm)	C (mm)	D (mm)	List Price
DT10111500511	OD	1:1	ER-40	----	91	91	94	72	\$4,500.00
DT10111500521	OD	1:1	ER-40	1500 PSI	91	91	100	72	\$5,500.00
DT10121500511	OD	1:2	ER-40	----	91	91	94	72	\$6,000.00
DT10121500521	OD	1:2	ER-40	1500 PSI	91	91	100	72	\$7,000.00
DT10141500511	OD	2:1	ER-40	----	91	91	94	72	\$6,000.00
DT10141500521	OD	2:1	ER-40	1500 PSI	91	91	100	72	\$7,000.00
DT10110500511	OD	1:1	KM-50	----	93	109	---	72	\$7,500.00
DT10110500521	OD	1:1	KM-50	1500 PSI	93	109	---	72	\$8,500.00

NEXUS QUICK TURN SERIES

QTN100-II M (MS - MY - MSY)

LIVE TOOLS

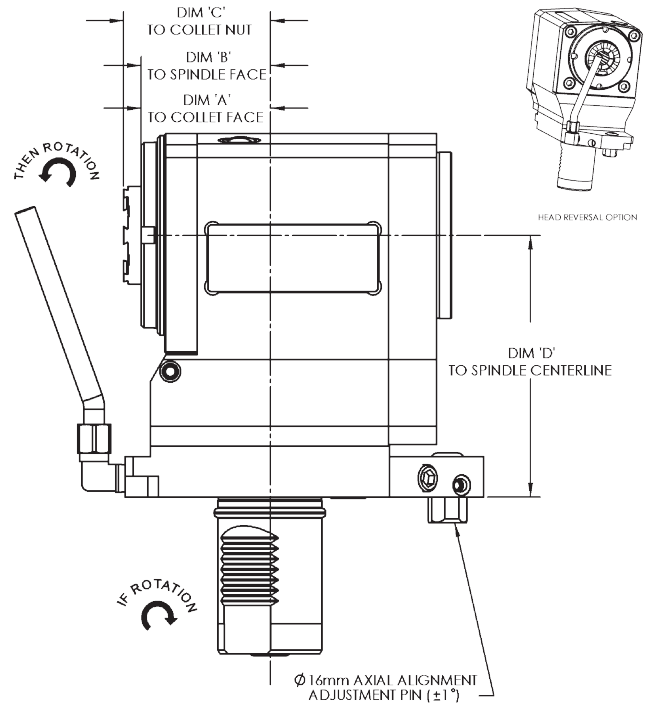

RIGHT-ANGLE (HORIZONTAL)

Item Number	Tool Axis	Ratio	Spindle	Internal Coolant	A (mm)	B (mm)	C (mm)	D (mm)	List Price
DT10211400111	FACE	1:1	ER-32	----	50	50	52	100	\$3,500.00
DT10211400121	FACE	1:1	ER-32	1500 PSI	50	50	58	100	\$4,500.00
DT10221400111	FACE	1:2	ER-32	----	50	50	52	100	\$5,000.00
DT10221400121	FACE	1:2	ER-32	1500 PSI	50	50	58	100	\$6,000.00
DT10241400111	FACE	2:1	ER-32	----	50	50	52	100	\$5,000.00
DT10241400121	FACE	2:1	ER-32	1500 PSI	50	50	58	100	\$6,000.00
DT10411400111	FACE-HR	1:1	ER-32	----	50	50	52	100	\$3,500.00
DT10411400121	FACE-HR	1:1	ER-32	1500 PSI	50	50	58	100	\$4,500.00
DT10421400111	FACE-HR	1:2	ER-32	----	50	50	52	100	\$5,000.00
DT10421400121	FACE-HR	1:2	ER-32	1500 PSI	50	50	58	100	\$6,000.00
DT10441400111	FACE-HR	2:1	ER-32	----	50	50	52	100	\$5,000.00
DT10441400121	FACE-HR	2:1	ER-32	1500 PSI	50	50	58	100	\$6,000.00
DT10210600111	FACE	1:1	KM-40	----	28	40	---	100	\$5,500.00
DT10210600121	FACE	1:1	KM-40	1500 PSI	28	40	---	100	\$6,500.00
DT10410600111	FACE-HR	1:1	KM-40	----	28	40	---	100	\$5,500.00
DT10410600121	FACE-HR	1:1	KM-40	1500 PSI	28	40	---	100	\$6,500.00

QTN100-II M (MS - MY - MSY)

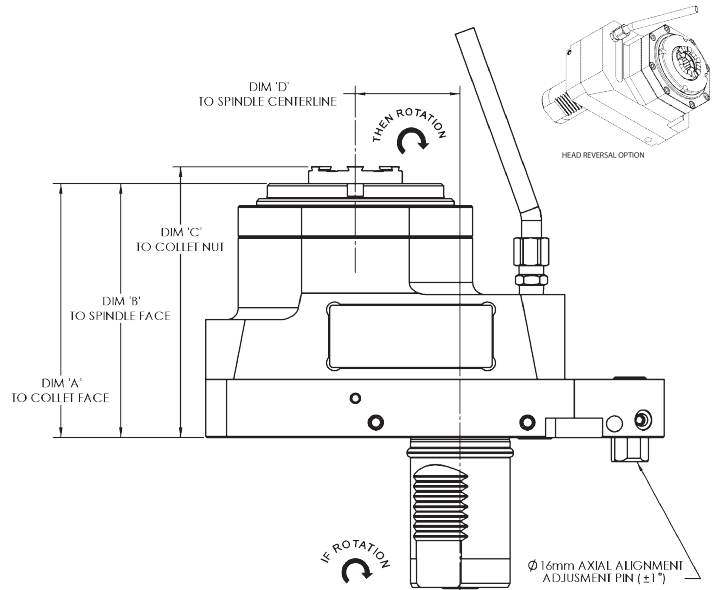

LIVE TOOLS

STRAIGHT-OFFSET (VERTICAL)

Item Number	Tool Axis	Ratio	Spindle	Internal Coolant	A (mm)	B (mm)	C (mm)	D (mm)	List Price
DT10111400111	OD	1:1	ER-32	----	102	102	104	42	\$3,500.00
DT10111400121	OD	1:1	ER-32	1500 PSI	102	102	110	42	\$4,500.00
DT10121400111	OD	1:2	ER-32	----	102	102	104	42	\$5,000.00
DT10121400121	OD	1:2	ER-32	1500 PSI	102	102	110	42	\$6,000.00
DT10141400111	OD	2:1	ER-32	----	102	102	104	42	\$5,000.00
DT10141400121	OD	2:1	ER-32	1500 PSI	102	102	110	42	\$6,000.00
DT10311400111	OD-HR	1:1	ER-32	----	102	102	104	42	\$3,500.00
DT10311400121	OD-HR	1:1	ER-32	1500 PSI	102	102	110	42	\$4,500.00
DT10321400111	OD-HR	1:2	ER-32	----	102	102	104	42	\$5,000.00
DT10321400121	OD-HR	1:2	ER-32	1500 PSI	102	102	110	42	\$6,000.00
DT10341400111	OD-HR	2:1	ER-32	----	102	102	104	42	\$5,000.00
DT10341400121	OD-HR	2:1	ER-32	1500 PSI	102	102	110	42	\$6,000.00
DT10110600111	OD	1:1	KM-40	----	90	102	---	42	\$5,500.00
DT10110600121	OD	1:1	KM-40	1500 PSI	90	102	---	42	\$6,500.00
DT10310600111	OD-HR	1:1	KM-40	----	90	102	---	42	\$5,500.00
DT10310600121	OD-HR	1:1	KM-40	1500 PSI	90	102	---	42	\$6,500.00



MAZAK

NEXUS QUICK TURN SERIES

QTN200-II M (MS - MY - MSY)

QTN250-II M (MS - MY - MSY)

LIVE TOOLS

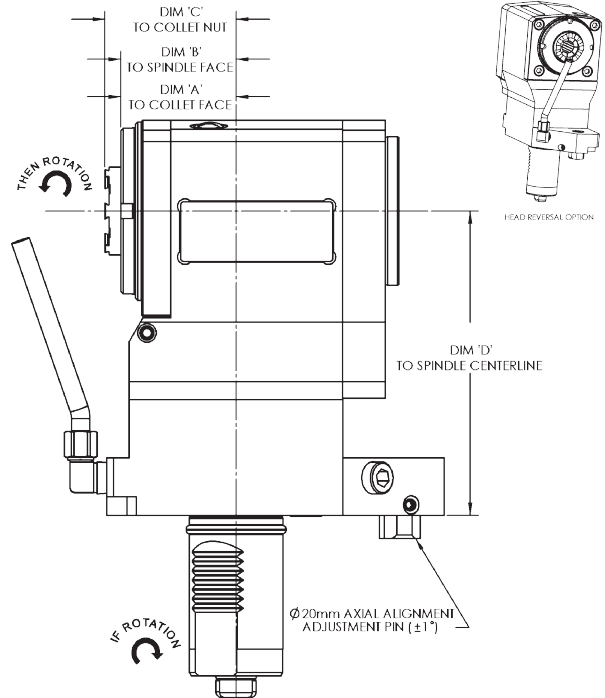

RIGHT-ANGLE (HORIZONTAL)

Item Number	Tool Axis	Ratio	Spindle	Internal Coolant	A (mm)	B (mm)	C (mm)	D (mm)	List Price
DT10211400211	FACE	1:1	ER-32	----	50	50	52	130	\$3,500.00
DT10211400221	FACE	1:1	ER-32	1500 PSI	50	50	58	130	\$4,500.00
DT10221400211	FACE	1:2	ER-32	----	50	50	52	130	\$5,000.00
DT10221400221	FACE	1:2	ER-32	1500 PSI	50	50	58	130	\$6,000.00
DT10241400211	FACE	2:1	ER-32	----	50	50	52	130	\$5,000.00
DT10241400221	FACE	2:1	ER-32	1500 PSI	50	50	58	130	\$6,000.00
DT10411400211	FACE-HR	1:1	ER-32	----	50	50	52	130	\$3,500.00
DT10411400221	FACE-HR	1:1	ER-32	1500 PSI	50	50	58	130	\$4,500.00
DT10421400211	FACE-HR	1:2	ER-32	----	50	50	52	130	\$5,000.00
DT10421400221	FACE-HR	1:2	ER-32	1500 PSI	50	50	58	130	\$6,000.00
DT10441400211	FACE-HR	2:1	ER-32	----	50	50	52	130	\$5,000.00
DT10441400221	FACE-HR	2:1	ER-32	1500 PSI	50	50	58	130	\$6,000.00
DT10210600211	FACE	1:1	KM-40	----	28	40	---	130	\$5,500.00
DT10210600221	FACE	1:1	KM-40	1500 PSI	28	40	---	130	\$6,500.00
DT10410600211	FACE-HR	1:1	KM-40	----	28	40	---	130	\$5,500.00
DT10410600221	FACE-HR	1:1	KM-40	1500 PSI	28	40	---	130	\$6,500.00

NEXUS QUICK TURN SERIES

QTN200-II M (MS - MY - MSY)

QTN250-II M (MS - MY - MSY)

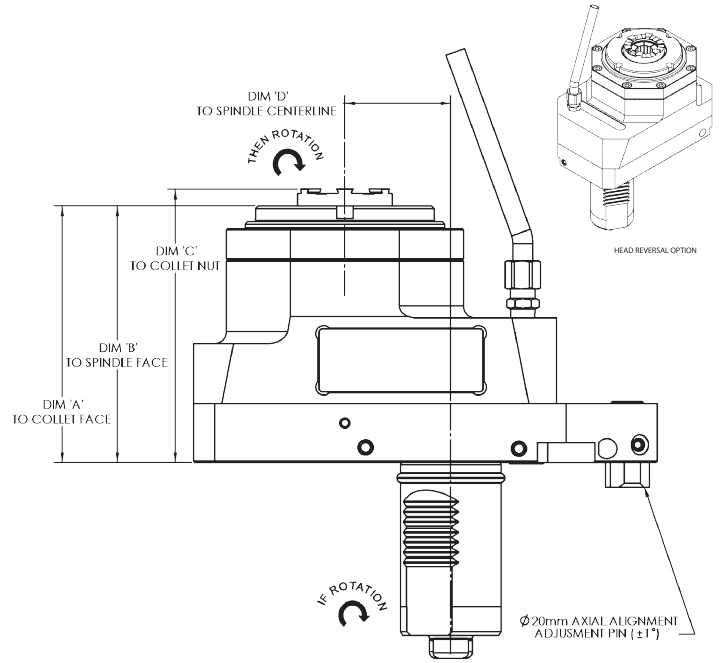

LIVE TOOLS

STRAIGHT-OFFSET (VERTICAL)

Item Number	Tool Axis	Ratio	Spindle	Internal Coolant	A (mm)	B (mm)	C (mm)	D (mm)	List Price
DT10111400211	OD	1:1	ER-32	----	102	102	104	42	\$3,500.00
DT10111400221	OD	1:1	ER-32	1500 PSI	102	102	110	42	\$4,500.00
DT10121400211	OD	1:2	ER-32	----	102	102	104	42	\$5,000.00
DT10121400221	OD	1:2	ER-32	1500 PSI	102	102	110	42	\$6,000.00
DT10141400211	OD	2:1	ER-32	----	102	102	104	42	\$5,000.00
DT10141400221	OD	2:1	ER-32	1500 PSI	102	102	110	42	\$6,000.00
DT10311400211	OD-HR	1:1	ER-32	----	102	102	104	42	\$3,500.00
DT10311400221	OD-HR	1:1	ER-32	1500 PSI	102	102	110	42	\$4,500.00
DT10321400211	OD-HR	1:2	ER-32	----	102	102	104	42	\$5,000.00
DT10321400221	OD-HR	1:2	ER-32	1500 PSI	102	102	110	42	\$6,000.00
DT10341400211	OD-HR	2:1	ER-32	----	102	102	104	42	\$5,000.00
DT10341400221	OD-HR	2:1	ER-32	1500 PSI	102	102	110	42	\$6,000.00
DT10110600211	OD	1:1	KM-40	----	90	102	---	42	\$5,500.00
DT10110600221	OD	1:1	KM-40	1500 PSI	90	102	---	42	\$6,500.00
DT10310600211	OD-HR	1:1	KM-40	----	90	102	---	42	\$5,500.00
DT10310600221	OD-HR	1:1	KM-40	1500 PSI	90	102	---	42	\$6,500.00



NEXUS QUICK TURN SERIES

QTN300-II M QTN350-II M (MY)
 QTN400-II M QTN450-II M

LIVE TOOLS

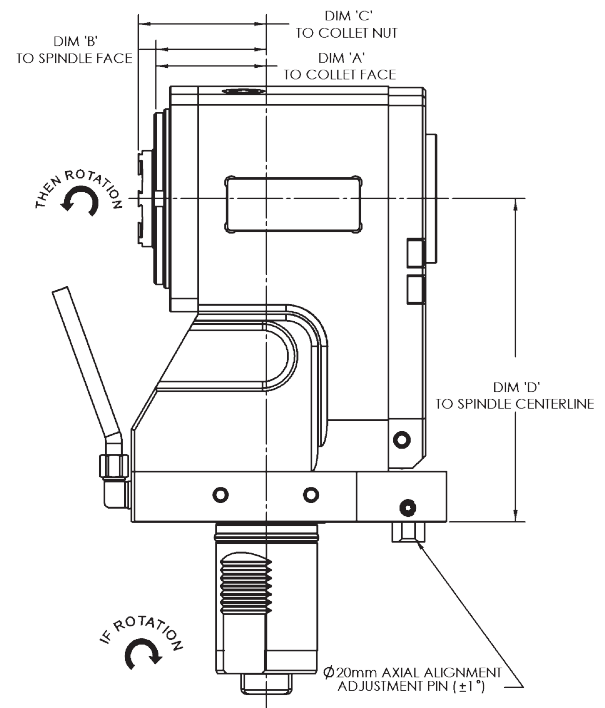

RIGHT-ANGLE (HORIZONTAL)

Item Number	Tool Axis	Ratio	Spindle	Internal Coolant	A (mm)	B (mm)	C (mm)	D (mm)	List Price
DT10211500611	FACE	1:1	ER-40	----	55	55	58	160	\$4,500.00
DT10211500621	FACE	1:1	ER-40	1500 PSI	55	55	64	160	\$5,500.00
DT10221500611	FACE	1:2	ER-40	----	55	55	58	160	\$6,000.00
DT10221500621	FACE	1:2	ER-40	1500 PSI	55	55	64	160	\$7,000.00
DT10241500611	FACE	2:1	ER-40	----	55	55	58	160	\$6,000.00
DT10241500621	FACE	2:1	ER-40	1500 PSI	55	55	64	160	\$7,000.00
DT10210500611	FACE	1:1	KM-50	----	32	48	---	160	\$7,500.00
DT10210500621	FACE	1:1	KM-50	1500 PSI	32	48	---	160	\$8,500.00

NEXUS QUICK TURN SERIES

QTN300-II M QTN350-II M (MY)
 QTN400-II M QTN450-II M

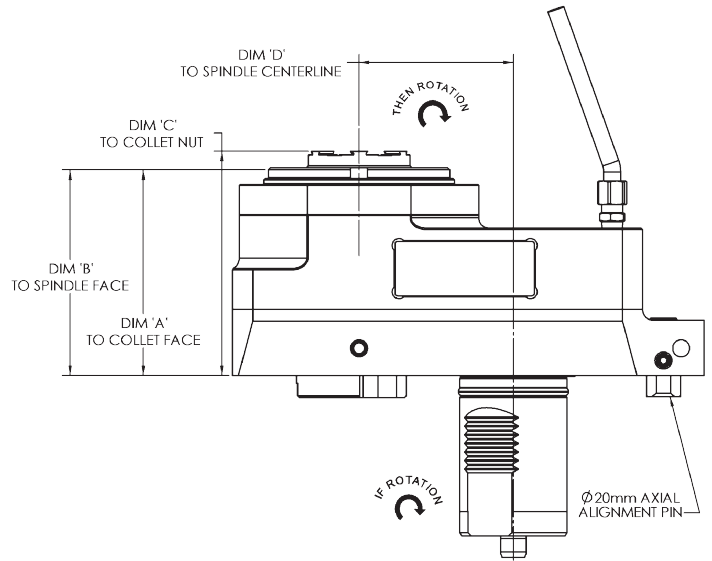
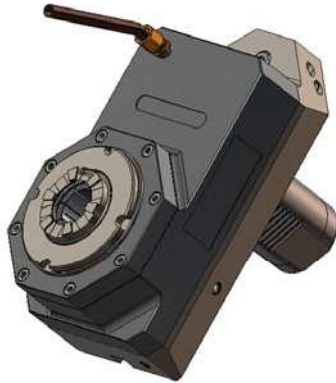

LIVE TOOLS

STRAIGHT-OFFSET (VERTICAL)

Item Number	Tool Axis	Ratio	Spindle	Internal Coolant	A (mm)	B (mm)	C (mm)	D (mm)	List Price
DT10111500611	OD	1:1	ER-40	----	96	96	99	72	\$4,500.00
DT10111500621	OD	1:1	ER-40	1500 PSI	96	96	105	72	\$5,500.00
DT10121500611	OD	1:2	ER-40	----	96	96	99	72	\$6,000.00
DT10121500621	OD	1:2	ER-40	1500 PSI	96	96	105	72	\$7,000.00
DT10141500611	OD	2:1	ER-40	----	96	96	99	72	\$6,000.00
DT10141500621	OD	2:1	ER-40	1500 PSI	96	96	105	72	\$7,000.00
DT10110500611	OD	1:1	KM-50	----	99	114	---	72	\$7,500.00
DT10110500621	OD	1:1	KM-50	1500 PSI	99	114	---	72	\$8,500.00



MAZAK

HYPER QUADREX SERIES MULTIPLEX SERIES QUICK TURN NEXUS SERIES

Why do over 94% of our test programs result in customer purchases....?



Designed, manufactured and supported in the USA for a Mazak customer by a Mazak customer.



Your only supplier with over 60 years of gear and bearing expertise combined with over 30 years of hydraulic expertise.



All tools are designed to each specific machine as to not limit your equipment's capabilities.



Quality high precision spindle bearings (ABEC 7 / P4 minimum) are used for performance, rigidity and durability for smooth operation and long life giving the assurance of solid performance.



Maximum use of each machine's turret cone for larger diameter duplex bearings set around the clamping system without interference to neighboring tools.



Highest quality seals and o-rings for protection against external contamination. Long-life premium grease for optimum lubrication environment.



Recessed spindle configurations reduces the length of moment arm for longer bearing life while maximizing tool lengths.



Bodies are made of high quality steels with a one piece base for maximum rigidity and wear resistance. Black oxide coated and/or melonited for a professional finish.



Internal and External combination coolant options. High pressure internal coolant option up to 1,500 PSI.



Hardened and honed right-angle spiral bevel and spur cut gears provide for long life, high strength and quiet operation.



Industry proven ER Tooling System for reliable and controlled machining. Wrenches Included!



All tools are packaged with specification sheets, operating instructions and audit-test reports.



Kennameta® Modular Quick-Change Tooling System for reliable and efficient tool changes.



48 Hour Service on repairs! We have even done them in less than one hour. We understand your urgency as we are a customer too!

